

# Self-Clinching Top Collar Lock Nuts

## Series CPL & CPLC

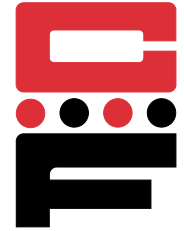

CPL top collar lock nuts combine reliable self-clinching mounting with a reusable non-metallic thread locking element.

Series	Material	Finish	Locking Element
CPL	Heat-treated Carbon Steel	Zinc* Clear	Clear Nylon
CPLC	300 Series Stainless Steel	Passivated ASTM A967	Clear Nylon

\*See Finish Spec. on Page 6.

Thread: Internal 2B, ANSI B1.1 (6H, ANSI/ASME B1.13M).

Use in: Material with Rockwell Hardness of B-70 or less.

### Note 1. Installation Tips

**Thin Sheets:** May be installed in panel thickness of .040 to .059 in. (1mm to 1.5mm) if fastener is partially installed in sheet. The knurled collar must be raised above sheet by the difference in thickness from .059 in. (1.5mm).

**Thick Sheets:** If fastener is installed in sheet greater than .070 in. (1.7mm), knurled collar may crack if mating screw is tightened above maximum torque limit.

**Note 2.** Thread locking performance for CPL & CPLC is equivalent to applicable NASM25027 specifications.

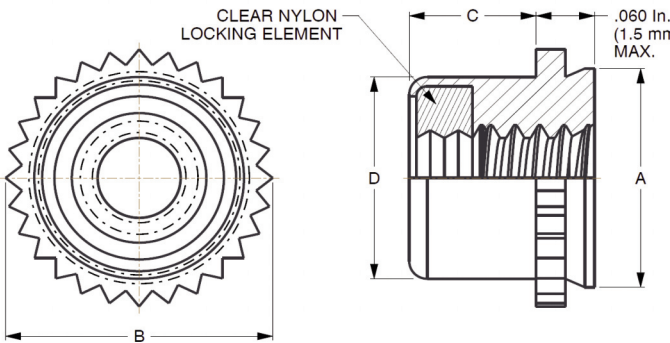

### Dimensions & Specifications

Thread Size	Part Number		Thickness Range	See Note 1 	A Max.	B Max.	C Max.	D Max.	Min.	
	Carbon Steel	Stainless Steel								
INCH (in.)	#4-40	CPL440	CPLC440	.040-.070	.234	.233	.274	.130	.215	.132
	#6-32	CPL632	CPLC632	.040-.070	.265	.264	.305	.130	.246	.158
	#8-32	CPL832	CPLC832	.040-.070	.297	.296	.338	.155	.278	.184
	#10-32	CPL1032	CPLC1032	.040-.070	.312	.311	.353	.165	.293	.210
METRIC (mm)	M3 x 0.5	CPLM3	CPLCM3	1-1.78	6.0	5.98	7.01	3.56	5.52	4.32
	M4 x 0.7	CPLM4	CPLCM4	1-1.78	7.5	7.48	8.54	4.2	7.01	5.59
	M5 x 0.8	CPLM5	CPLCM5	1-1.78	8.0	7.98	9.0	4.45	9.52	6.35

Continued on next page.





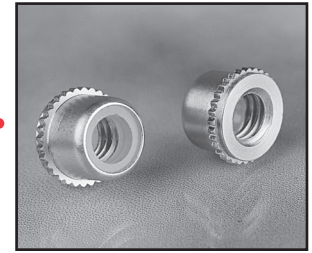

# Self-Clinching Top Collar Lock Nuts

## Series CPL & CPLC

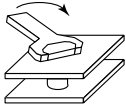
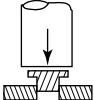

Continued from previous page.

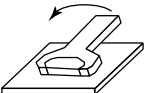
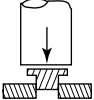
### Installation & Performance Data

	.048 in. Cold-rolled Steel				.060 in. Cold-rolled Steel				
	 Max. Tightening Torque (in.-lbs.)	 Installation Force (lbs.)	 Pushout (lbs.)	 Torque-out (in.-lbs.)	 Installation Force (lbs.)	 Pushout (lbs.)	 Torque-out (in.-lbs.)		
INCH (in.)	#4-40	9.3	3000	225	20	3000	260	20	
	#6-32	12.9	3000	270	30	3000	290	30	
	#8-32	19.1	3000	270	60	3000	290	60	
	#10-32	26	3000	310	70	3000	350	70	
		.060 in. 5052H34 Aluminum				.040 in. 5052H34 Aluminum			
		Max. Tightening Torque (in.-lbs.)	Installation Force (lbs.)	Pushout (lbs.)	Torque-out (in.-lbs.)	Installation Force (lbs.)	Pushout (lbs.)	Torque-out (in.-lbs.)	
	#4-40	9.3	2000	225	20	1500	160	20	
	#6-32	12.9	2000	285	30	1500	180	25	
	#8-32	19.1	2000	290	60	1500	180	28	
	#10-32	26	2000	300	70	1500	180	40	
		1.5mm Cold-rolled Steel				1.2mm Cold-rolled Steel			
		Max. Tightening Torque (N•m)	Installation Force (kN)	Pushout (N)	Torque-out (N•m)	Installation Force (kN)	Pushout (N)	Torque-out (N•m)	
M3	1.13	13.34	1156	2.25	13.34	1000	2.25		
M4	2.3	13.34	1290	6.77	13.34	1200	6.77		
M5	3.12	13.34	1557	7.9	13.34	1380	7.9		
	1.5mm 5052H34 Aluminum				1.0mm 5052H34 Aluminum				
	Max. Tightening Torque (N•m)	Installation Force (kN)	Pushout (N)	Torque-out (N•m)	Installation Force (kN)	Pushout (N)	Torque-out (N•m)		
M3	1.13	8.90	1000	2.25	6.67	710	2.25		
M4	2.3	8.90	1290	6.77	6.67	800	3.16		
M5	3.12	8.90	1330	7.9	6.67	800	4.51		