

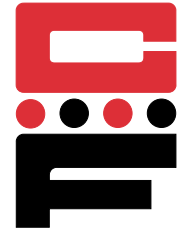

Self-Clinching Miniature Self Locking Nuts



Series CFE & CFEO Self-Locking Threads CFEX & CFEOX Non-Locking Threads

CFE self-clinching fasteners are designed to provide strong threads in a minimum of space. They are available with locking and non-locking threads and are directly interchangeable with industry standards.

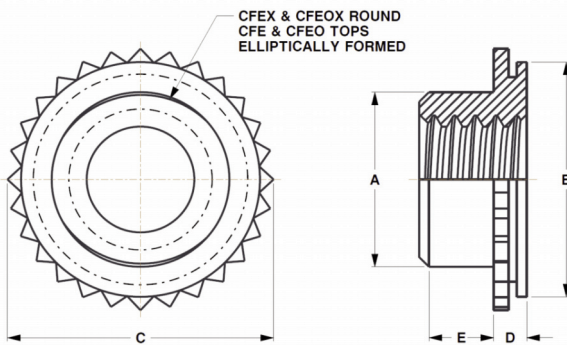

Series	Finish	Thread
CFE,CFEO	Black Dry Film Lubricant (ML)	Self-Locking Internal 3B, ANSI B1.1 (6H,ANSI/ASME B1.13M)
CFEX,CFEOX	Passivated ASTM A967	Non-Locking Internal 2B, ANSI B1.1 (6H,ANSI/ASME B1.13M)

Material: 300 Series Stainless Steel.

Use in: Materials with Rockwell Hardness of B-70 or less.

Note: Thread locking performance for CFE & CFEO is equivalent to applicable NASM25027 specifications.

Dimensions & Specifications

Thread Size	Part Number		D Max.	Min.	+0.003 in. (.08 mm) -0.000(.00)	A Max.	E +.015 in. (.4 mm) -.000(.00)	B Max.	C ±.005 in. (.13 mm)	Min.	
	Self-Locking	Non-Locking									
INCH (in.)	#4-40	CFE440	CFEX440	.060	.059	.172	.145	.065	.171	.192	.14
		CFEO440	CFEOX440	.040	.039						
	#6-32	CFE632	CFEX632	.060	.059	.213	.180	.075	.212	.244	.17
		CFEO632	CFEOX632	.040	.039						
	#8-32	CFE832	CFEX832	.060	.059	.290	.215	.090	.289	.322	.20
		CFEO832	CFEOX832	.040	.039						
#10-32	CFE1032	CFEX1032	.060	.059	.290	.245	.110	.289	.322	.20	
	CFEO1032	CFEOX1032	.040	.039							
1/4-20	CFE420	CFEX420 ¹	.060	.059	.344	.318	.120	.343	.384	.28	
1/4-28	CFE428	CFEX428 ¹	.060	.059							
METRIC (mm)	M3 x 0.5	CFEOM3	CFEOXM3	1.02	.99	4.39	3.96	1.90	4.37	4.88	3.6
		CFEM3	CFEXM3	1.53	1.5						
	M4 x 0.7	CFEOM4	CFEOXM4	1.02	.99	7.39	5.23	2.55	7.37	8.17	5.2
		CFEM4	CFEXM4	1.53	1.5						
	M5 x 0.8	CFEOM5	CFEOXM5	1.02	.9	7.39	6.48	3.05	7.37	8.17	5.2
		CFEM5	CFEXM5	1.53	1.5						
M6 x 1.0	CFEM6	CFEXM6	1.53	1.5	8.74	7.72	3.30	8.72	9.74	7.1	

¹Not Stocked, available on special order.

Continued on next page.



Self-Clinching Miniature Self Locking Nuts



**Series CFE & CFEO
Self-Locking Threads
CFEX & CFEOX
Non-Locking Threads**

Continued from previous page.

Installation & Performance Data

Thread Size	Series	Sheet Thickness	Cold-rolled Steel			5052-H34 Aluminum			
			Installation Force (lbs.)	Pushout (lbs.)	Torque-out (in.-lbs.)	Installation Force (lbs.)	Pushout (lbs.)	Torque-out (in.-lbs.)	
INCH (in.)	#4-40	CFEO, CFEOX	.040	1500	140	12	900	88	12
		CFE, CFEX	.060	1500	210	12	900	135	12
	#6-32	CFEO, CFEOX	.040	2100	185	20	1200	105	20
		CFE, CFEX	.060	2100	255	20	1300	175	20
	#8-32	CFEO, CFEOX	.040	2500	260	48	1500	155	48
		CFE, CFEX	.060	2500	360	48	1500	255	48
#10-32	CFEO, CFEOX	.040	2500	260	48	1500	155	48	
	CFE, CFEX	.060	2500	360	48	1500	255	48	
1/4-20 1/4-28	CFE, CFEX	.060	3500	420	110	2100	320	110	
Thread Size	Series	Sheet Thickness	Cold-rolled Steel			5052-H34 Aluminum			
			Installation Force (kN)	Pushout (N)	Torque-out (N•m)	Installation Force (kN)	Pushout (N)	Torque-out (N•m)	
METRIC (mm)	M3	CFEO, CFEOX	1.0	6.7	622	1.35	4.0	391	1.35
		CFE, CFEX	1.5	6.7	934	1.35	4.0	590	1.3
	M4	CFEO, CFEOX	1.0	11.1	1156	5.42	6.7	689	5.42
		CFE, CFEX	1.5	11.1	1601	5.42	6.7	1134	5.42
	M5	CFEO, CFEOX	1.0	11.1	1156	5.42	6.7	689	5.42
		CFE, CFEX	1.5	11.1	1601	5.42	6.7	1134	5.42
M6	CFE, CFEX	1.5	15.6	1864	12.43	9.4	1423	12.43	