

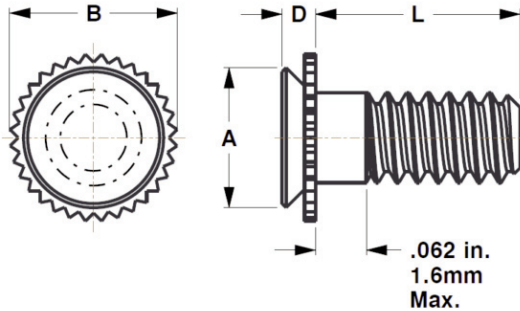

Self-Clinching Studs Concealed-Head Series CFA & CFC



CFA & CFC concealed-head studs allow permanent mounting in thin metal sheets, using a hollow punch and solid anvil. The stud head is pressed permanently into a blind milled hole, with no marring of the exterior surface.



Series	Material	Finish
CFA	2024-T4 Aluminum	None
CFC	300 Series Stainless Steel	Passivated ASTM A967

Thread: External 2A, ANSI B1.1 (6g ANSI/ASME B1.13M).*

Use in: CFA - HRB-50 or less.
CFC - HRB-70 or less.

Part Number Structure:

CFA-1-440-4



*See Note 3 on Page 6 for Gauging Spec.

Dimensions & Specifications

INCH (in.)	Thread Size	Material		Thread Code	L Length ±.015 (Length Code is in 16ths of an inch)						Min.	Blind Mounting Hole Dia. +.003 -.000	Min. Depth Of Blind Hole	D Max.	B ±.010	A Max.	Min.	Max. Hole in Attached Parts
		Aluminum	Stainless Steel		.250	.375	.500	.625	.750	1.00								
		CFA-1	CFC-1		CFA-2	CFC-2												
#4-40	CFA-1	CFC-1	440	-4	-6	-8	-10	-12		.062	.172	.043	.041	.205	.171	.156	.135	
	CFA-2	CFC-2		-4	-6	-8	-10	-12		.093								
#6-32	CFA-1	CFC-1	632	-4	-6	-8	-10	-12	-16	.062	.213	.043	.041	.250	.212	.188	.160	
	CFA-2	CFC-2		-4	-6	-8	-10	-12	-16	.093								
#8-32	CFA-1	CFC-1	832	-4	-6	-8	-10	-12	-16	.062	.290	.043	.041	.328	.289	.219	.185	
	CFA-2	CFC-2		-4	-6	-8	-10	-12	-16	.093								
#10-32	CFA-1	CFC-1	1032		-6	-8	-10	-12	-16	.062	.312	.043	.041	.350	.311	.250	.210	
	CFA-2	CFC-2			-6	-8	-10	-12	-16	.093								

Dimensions & Specifications

METRIC (mm)	Thread Size	Material		Thread Code	L Length ±.4 (Length Code is in mm)							Min.	Blind Mounting Hole Dia. +.08 -.00	Min. Depth Of Blind Hole	D Max.	B ±.25	A Max.	Min.	Max. Hole in Attached Parts
		Aluminum	Stainless Steel		6	8	10	12	16	20	25								
		CFA-1	CFC-1		CFA-2	CFC-2													
M3x0.5	CFA-1	CFC-1	M3	-6	-8	-10	-12	-16	-20		1.6	4.37	1.1	1.04	5.21	4.35	4	3.6	
	CFA-2	CFC-2		-6	-8	-10	-12	-16	-20		2.4								
M4x0.7	CFA-1	CFC-1	M4	-6	-8	-10	-12	-16	-20	-25	1.6	7.37	1.1	1.04	8.33	7.35	5.6	4.6	
	CFA-2	CFC-2		-6	-8	-10	-12	-16	-20	-25	2.4								
M5x0.8	CFA-1	CFC-1	M5			-10	-12	-16	-20	-25	1.6	7.93	1.1	1.04	8.89	7.9	6.4	5.6	
	CFA-2	CFC-2				-10	-12	-16	-20	-25	2.4								

†Not stocked, available on special order.

Continued on next page.



Self-Clinching Studs Concealed-Head Series CFA & CFC



Continued from previous page.

Installation & Performance Data

	Type	Thread Code	Tightening Torque Max. (in.-lbs.)	Sheet Material			
				Cold-rolled Steel		5052-H34 Aluminum	
				Installation Force (lbs.)	Pullout (lbs.)	Installation Force (lbs.)	Pullout (lbs.)
INCH (in.)	CFC-1	440	4.75	4000	300	2800	200
		632	8.75	4500	350	3000	240
		832	18	4800	400	4000	270
		1032	32	5500	450	5000	290
	CFC-2	440	4.75	4300	350	2900	220
		632	8.75	5000	360	3200	240
		832	18	5300	440	4000	300
		1032	32	6000	600	5000	430
	CFA-1	440	2.85	N/A	N/A	1400	130
		632	5.4	N/A	N/A	1800	160
		832	10.8	N/A	N/A	2800	180
		1032	19.2	N/A	N/A	4000	210
	CFA-2	440	2.85	N/A	N/A	1500	200
		632	5.4	N/A	N/A	2500	260
		832	10.8	N/A	N/A	3000	310
		1032	19.2	N/A	N/A	3500	300

	Type	Thread Code	Max. (N•m)				
				(kN)	(N)	(kN)	(N)
METRIC (mm)	CFC-1	M3	.5	8	1065	6.2	575
		M4	2	17.8	1200	12.5	800
		M5	3.6	22.2	1290	17.8	930
	CFC-2	M3	.5	8.9	1065	6.7	890
		M4	2	14.7	1955	13.3	1375
		M5	3.6	17.8	3020	15.6	1600
	CFA-1	M3	.3	N/A	N/A	6.2	555
		M4	1.2	N/A	N/A	12.5	645
		M5	2.16	N/A	N/A	17.8	755
	CFA-2	M3	.3	N/A	N/A	6.7	845
		M4	1.2	N/A	N/A	13.3	1065
		M5	2.16	N/A	N/A	15.6	1330



Self-Clinching Studs Concealed-Head Series CFA & CFC Typical Installation Method



Continued from previous page.

Installation Procedure

1. Mill a blind hole in material to specified depth.*
2. Place fastener into hole in anvil.
3. Place sheet material over head of fastener.
4. Apply a downward squeezing force with punch, pressing on sheet material until serrated collar of fastener is flush with surface.

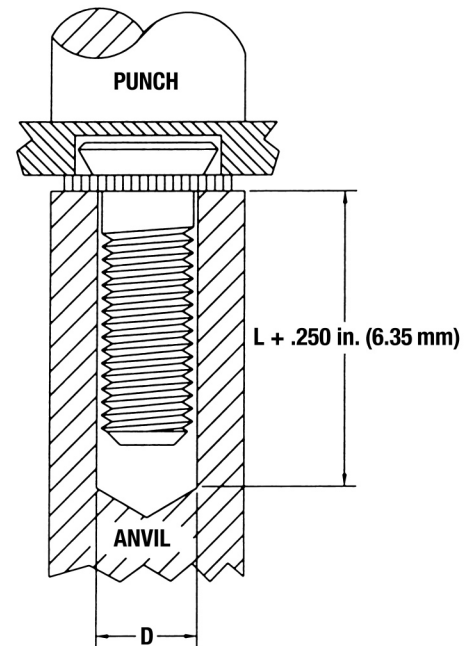

*Depth of blind holes may be greater than minimum, if sheet thickness allows.

Anvil 'D' Diameter Dimensions for Concealed Head Studs

INCH (in.)	Series	Thread Code	D Dia. (in.)
	CFA CFC		440
		632	.152
		832	.179
		1032	.205

METRIC (mm)	Series	Thread Code	D Dia. (mm)
	CFA CFC		M3
		M4	4.4
		M5	5.4