



Self-Clinching Grounding Standoffs

Series CFSOSG & CFSOAG



CFSOSG & CFSOAG self-grounding standoffs are designed to be installed in steel and aluminum chassis to ground PC boards. Projecting teeth assure excellent electrical contact with PC board circuit and eliminate need for serrated or star washers.

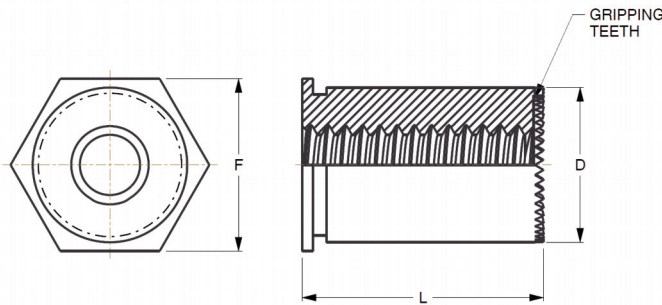

† Not stocked, available on special order.

Series	Material	Finish
CFSOSG	300 Series Stainless Steel	Passivated ASTM A967
CFSOAG	7075-T6 Aluminum	None

Thread: Internal 2B ANSI B1.1 (6H, ANSI/ASME B1.13M).

Use in: CFSOSG for materials with Rockwell Hardness of B-70 or less.

CFSOAG for materials with Rockwell Hardness of B-50 or less.

Dimensions & Specifications

INCH (in.)	Thread Size	Part Numbers		L Length +.010 -.000 in.							F Hex Dim. (Nom.)	D +.000 -.005		
		Stainless	Aluminum	.125	.187	.250	.312	.375	.437	.500				
	#4-40	CFSOSG6440	CFSOAG6440	-4 [†]	-6	-8	-10	-12	-14	-16	.250	.212	.213	.27
	#6-32	CFSOSG8632	CFSOAG8632	-4 [†]	-6 [†]	-8	-10	-12	-14	-16	.312	.280	.281	.31
METRIC (mm)	Thread Size	Part Numbers		L Length +.25 - .00 mm							F Hex Dim. (Nom.)	D +.00 -.13		
		Stainless	Aluminum	3	4	6	8	10	12	14				
	M3x0.5	CFSOSG3.5M3	CFSOAG3.5M3	-3	-4	-6	-8	-10	-12	-14	6.4	5.39	5.41	6.86

Installation & Performance Data

INCH (in.)	Thread Size	5052-H34 Aluminum			
		 Min.	 Installation Force (lbs.)	 Pushout (lbs.)	 Torque- out (in.-lbs.)
	#4-40	.040	1500-2000	300	25
	#6-32	.050	1500-2000	400	45
METRIC (mm)	Thread Size	Min.	Installation Force (kN)	Pushout (N)	Torque- out (N•m)
	M3	1.0	8	1330	2.82