

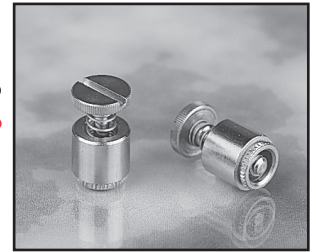

# Broaching Type Panel Fasteners

## Series CPFK



CPFK PC board panel fasteners provide permanent attachment of screw assemblies to PC board substrate material. Screw assemblies remain captive for easy mounting and removal of board.

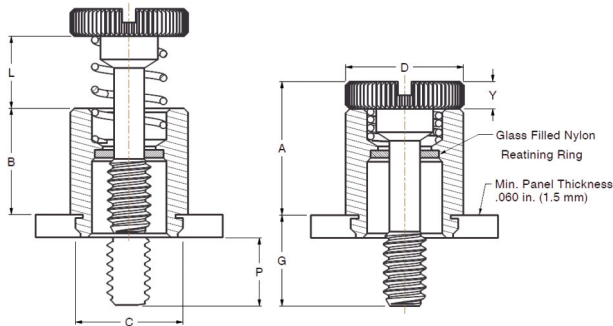

Series	Material	Finish
CPFK	300 Series Stainless Steel	Passivated ASTM A967

Thread: External 2A, ANSI B1.1 (6g ANSI/ASME B1.13M).\*  
Use in: PC Boards with Rockwell Hardness of B-70 or less.

\*See Note 3 on Page 6 for Gauging Spec.

### Dimensions & Specifications

Thread Size	Part Number	G ±.016 in. (.4 mm)	P ±.016 in. (.4 mm)	L ±.016 in. (.4 mm)	D +.016 in. (.4mm) -.010 in. (.25 mm)	A Max.	Y ±.005 in. (.13 mm)	B ±.010 in. (.25mm)	C ±.003 in. (.08mm)	 +.003 in. (.08 mm) -.000(.00)	Min.	
INCH (in.)	#4-40	CPFK440-40	.250	.000	.19	.312	.36	.072	.28	.283	.265	.20
		CPFK440-62	.375	.125								
		CPFK440-84	.500	.250								
	#6-32	CPFK632-40	.250	.000	.19	.344	.36	.072	.28	.299	.281	.26
		CPFK632-62	.375	.125								
		CPFK632-84	.500	.250								
METRIC (mm)	M3 x 0.5	CPFKM3-40	6.4	.0	4.8	7.92	9.14	1.83	7.2	7.19	6.73	5.8
		CPFKM3-62	9.5	3.2								
		CPFKM3-84	12.7	6.4								

### Installation & Performance Data

Thread Size	Fiberglass .060 in. (1.5 mm)		
	 Installation Force (lbs.)	 Pushout (lbs.)	 Torque-out (in.-lbs.)
INCH (in.)			
#4-40	250	55	(1)
#6-32	400	60	(1)
METRIC (mm)			
M3	1.1	245	(3)