

Hydro Pneumatic Riveter W4

Specifications

- Riveting Capacity: 4.8mm, 6.4mm standard blind rivets and Monobolt and Hemloc
- Stroke: 20mm
- Air Pressure: 5-7bar
- Full Force: 18KN@6bar
- Air consumption: 4.8ltr
- Noise Level: <75dB(A)
- Vibration: <2.5m/s²
- Weight: 1.7kg



Benefits

- Lightweight and powerful tool
- Small Shock, Low noise
- Integrated vacuum system
- Reduced operator fatigue
- High placement speed
- Enhanced tool life

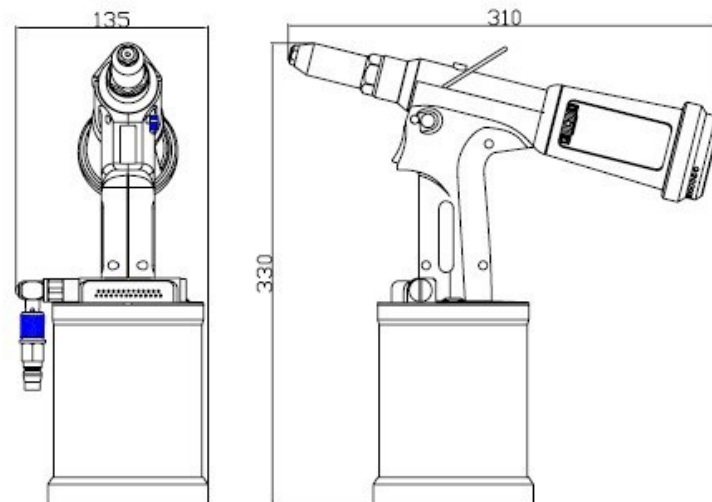

Note: Products in this catalogue are subject to availability