

Hydro Pneumatic Riveter G3

Specifications

- Riveting Capacity: 4.0mm, 4.8mm, 6.4mm standard blind rivets and monobolt
- Stroke: 26mm
- Air Pressure: 5-7bar
- Full Force: 15.20KN@6bar
- Air consumption: 4.8ltr
- Noise Level: <75dB(A)
- Vibration: <2.5m/s²
- Weight: 2.00kg



Benefits

- Lightweight and powerful tool
- Toughened plastic body and heavy duty rubber base
- Ergonomic
- Reduced operator fatigue
- High placement speed
- Minimized air consumption
- Places a wide range of fasteners
- Enhanced tool life

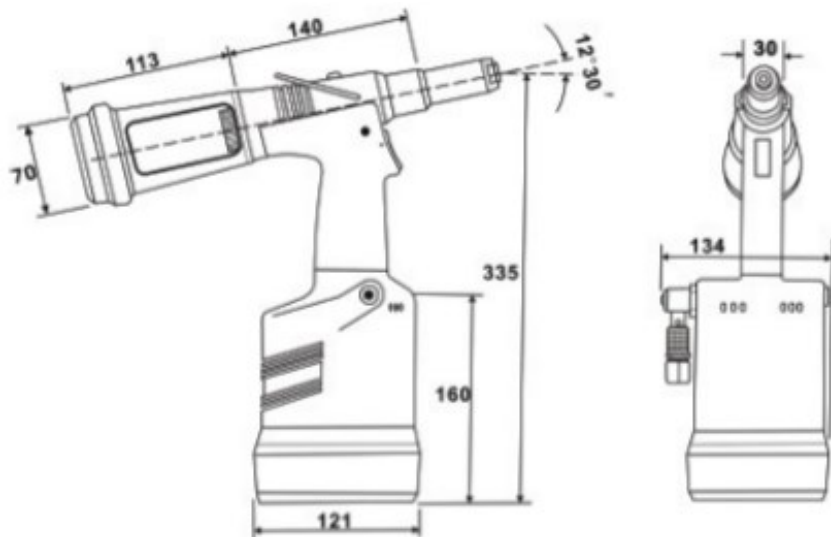

Note: Products in this catalogue are subject to availability



Head Office: Concept Fasteners VIC
 9 Flight Drive, Tullamarine 3043, Victoria
 Tel: (03) 9338 6633 Fax: (03) 9338 6433
 : sales@conceptfasteners.com.au

Head Office: Concept Fasteners NSW
 5 Liverpool St, Ingleburn 2565, NSW
 Tel: (02) 9774 4416
 : salesnsw@conceptfasteners.com.au

Head Office: Concept Fasteners QLD
 Brisbane Branch Coming Soon!
 : qldsales@conceptfasteners.com.au