

Hydro Pneumatic Riveter G2

Specifications

- Riveting Capacity 3.0mm, 3.2mm, 4.0mm, 4.8mm Standard blind rivets and monobolts
- Weight (without nose equip) 1.98kg
- Weight (min. with equip) 2.1kg
- Pull Force @ 5.5 bar 9.34 KN
- Stroke (min.) 17mm (0.67 in)
- Cycle time (approx.) 0.8 sec
- Air supply pressure 5-7 bar (80-100 psi)
- Free air volume @ 5.5 bar 2.1 litres
- Noise level <75 dB(A)
- Vibration <2.5m/s²



Benefits

- Reduced operator fatigue
- High placement speed
- Robust tool
- Minimized air consumption
- Reduced setting times and change of equipment
- Reduced time to empty stem collector
- Places a wide range of fasteners
- Ergonomic

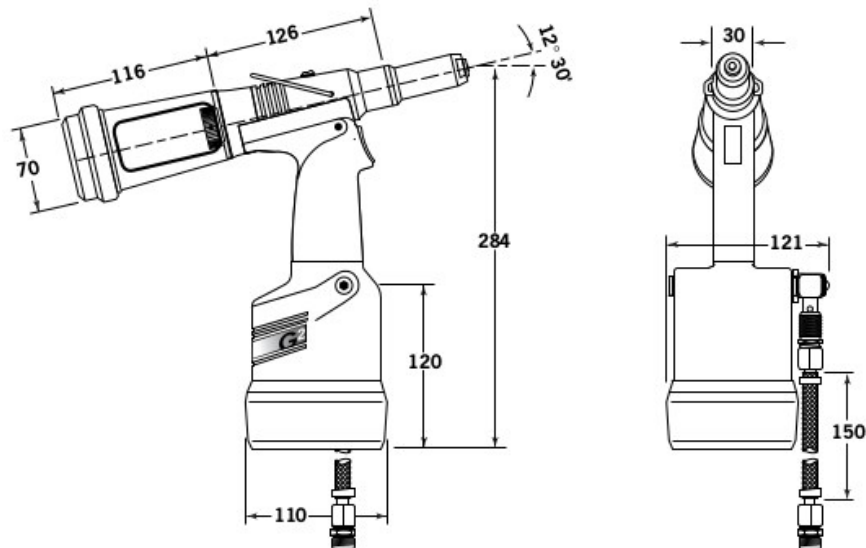

Note: Products in this catalogue are subject to availability



Head Office: Concept Fasteners VIC
 9 Flight Drive, Tullamarine 3043, Victoria
 Tel: (03) 9338 6633 Fax: (03) 9338 6433
 ✉ : sales@conceptfasteners.com.au

Concept Fasteners NSW
 5 Liverpool St, Ingleburn 2565, NSW
 Tel: (02) 9774 4416
 ✉ : salesnsw@conceptfasteners.com.au

Concept Fasteners QLD
 Brisbane Branch Coming Soon!
 ✉ : qldsales@conceptfasteners.com.au